

# Ultimate Failure Load and Stiffness of Screw Jointed Furniture Cabinets Constructed of Particleboard and Medium-Density Fiberboard

Ali Kasal

Mehmet Yuksel

Ali Fathollahzadeh

Yusuf Ziya Erdil

Nadir Yildirim

---

## Abstract

The objective of this study was to investigate the effects of material type, screw diameter, and screw length on ultimate failure load and stiffness of four-sided furniture cabinets. In total, 81 four-sided test cabinets were constructed in 1/1 dimensions. Assembly of cabinets was done using nine different sizes of screws ranging from 3.5 by 40 mm to 5 by 50 mm. Panel materials were 18-mm-thick particleboard (PB) and 16- and 18-mm-thick medium-density fiberboard (MDF1, MDF2). Cabinets were anchored at two points located underneath the top panel and tested under static load. Loading procedures of the American National Standards Institute/Kitchen Cabinet Manufacturers Association were followed during the static tests. Test results showed that 18- and 16-mm MDF cabinets yielded higher failure loads and stiffness values compared with the 18-mm PB cabinets. Test results also indicated that increasing either screw diameter or screw length tended to have a positive effect on the failure load and stiffness values. The strongest and most rigid four-sided cabinets were obtained with 4-mm-diameter and 50-mm-long screws if the construction panel material was 18-mm-thick MDF, 5-mm-diameter and 45-mm-long screws if the construction panel material was 16-mm-thick MDF, and 5-mm-diameter and 50-mm-long screws if the construction panel material was 18-mm-thick PB.

---

Wood-based panels such as medium-density fiberboard (MDF) and particleboard (PB) are widely used in manufacturing case-type furniture because the mechanical, physical, and surface qualities of these engineered panels are comparable to those of solid woods. Furthermore, general within and between panel properties are relatively uniform compared with solid wood. These characteristics make them suitable alternatives to solid wood for industrial manufacturing of furniture such as modern upholstered furniture, office furniture, and kitchen cabinets. Furniture manufacturers can easily set up industrial scale manufacturing of case goods by using new industrial machinery and wood-based panels.

Joints are the weakest part in furniture (Eckelman, 2003) and require the most attention in furniture engineering research. Lin and Eckelman (1987) carried out a study to determine the effect of joint rigidity on case stiffness. Results indicated that case stiffness can be significantly influenced by joint type. New production approaches require additional research to examine the strength and durability of joints in case furniture.

Screws are commonly used in the construction of furniture cabinet corner joints. Rational design of cabinets constructed with screws requires information on the failure load and stiffness of these when using PB and MDF. The main consideration in the product engineering of screw

jointed cabinets is the specification of screw sizes that should be used in joining the sides to the bottom and top of the case. Despite their widespread use, limited information is available in relation to failure load and stiffness of screw-joint corner joints in cabinets.

Several investigations have been conducted to evaluate the joints-to-panel connection. Kotas (1957, 1958a) carried out the first known studies of the structural characteristics of case furniture. The results of his research were incorporated into a small design manual (Kotas, 1958b). Englesson (1973) investigated the strength of five different corner fasteners, including a butt dowel joint, a mitered joint with an included plastic angle, a mitered joint with dowels, a simple miter joint, and a miter joint with a spline. Of the

---

The authors are, respectively, Associate Professor and Instructor, Mugla Univ., Teknik Egitim Fakultesi, Kotekli, Mugla, Turkey (alikal@mu.edu.tr, myuksel@mu.edu.tr); PhD Candidate, Faculty of Natural Resources, Univ. of Tehran, Tehran, Iran (afzadeh@ut.ac.ir); and Professor and Instructor, Mugla Univ., Teknik Egitim Fakultesi, Kotekli, Mugla, Turkey (erdil@mu.edu.tr, nadiry@mu.edu.tr). This paper was received for publication in June 2010. Article no. 10-00018.

©Forest Products Society 2011.

Forest Prod. J. 61(2):155-160.

joints tested, the mitered joint with a spline gave the best results. The doweled miter joint also performed well.

The problem of greatest concern when constructing the joints with wood-based panels is the tendency of panel edges to delaminate. This is particularly true when butt-type joints are used. In tests conducted by Bachmann and Hassler (1975), delamination of the free edge of one panel was the principle source of failure with demountable fasteners that used metal and plastic inserts. Failure values obtained with screws that passed through the panel were nearly double those for the demountable fittings. Dowel constructions gave higher values than those for demountable hardware but less than for the fittings in which the screw passed entirely through the external panel. When the edge of the exposed panel was covered with mahogany veneer, however, the bending moment resistance of the dowel construction was 43 percent stronger than that of the through screw connection. The results of these tests provided evidence of the importance of considering natural characteristics of the material when designing with PB. In particular, it was necessary to design joints in such way that the tendency of the board to delaminate was minimized.

Lin and Eckelman (1987) carried out a study for determining the effect of joint rigidity on case stiffness. Results of their study indicated that joints do have a significant effect on stiffness and that manufacturers may want to use joints that provide the greatest stiffness in their construction. Kasal et al. (2008) studied the effects of screw size on load bearing capacity and stiffness of five-sided furniture cases constructed of MDF and PB. Five-sided cases were tested under static load by supporting at three points. Results indicated that MDF cases yielded significantly higher load bearing capacity than PB cases, but the significance of MDF cases' stiffness over that of PB cases depended mainly on screw diameter. Maximum load bearing capacity and stiffness in PB cases resulted when the longest and largest diameter screws were used in the test, which were 5 by 50 mm.

The goal of this research was to investigate the ultimate failure load and stiffness of four-sided furniture cabinets constructed of PB and MDF using different screw sizes in corner joints. The factors studied were

1. effect of panel type (PB, MDF) and thickness and
2. effect of screw size (diameter and length).

### Experimental Design

Overall, 27 sets of four-sided test cabinets, each replicated three times for a total of 81 four-sided test cabinets, were constructed for static testing (Table 1). A full linear model for the three-way factorial experiment was used to investigate the effect of panel type (18-mm-thick PB, 16- and 18-mm-thick MDF), screw diameter (3.5, 4, and 5 mm), and screw length (40, 45, and 50 mm) on the ultimate failure load and stiffness of the four-sided furniture cabinets. The model used was

$$FS_{ijkl} = \mu_1 + A_i + B_j + C_k + (AB)_{ij} + (AC)_{ik} + (BC)_{jk} + (ABC)_{ijk} + \varepsilon_{ijkl} \quad (1)$$

where  $FS_{ijkl}$  = ultimate failure load (N) or stiffness (N/mm);  $\mu$  = population mean ultimate failure load (N) or stiffness (N/mm);  $A$ ,  $B$ , and  $C$  = discrete variable representing effect

Table 1.—Specimen schedule used in the study.

Screw diameter (mm)	Screw length (mm)	18-mm MDF	18-mm PB	16-mm MDF	Total
3.5	40	3	3	3	9
	45	3	3	3	9
	50	3	3	3	9
4	40	3	3	3	9
	45	3	3	3	9
	50	3	3	3	9
5	40	3	3	3	9
	45	3	3	3	9
	50	3	3	3	9
Total	27	27	27	81	

of panel type, screw diameter, and screw length, respectively;  $(AB)$ ,  $(AC)$ ,  $(BC)$  = effect of the two-way interactions;  $(ABC)$  = effect of the three-way interactions;  $\varepsilon$  = random error term;  $i$ ,  $j$ ,  $k$ , and  $l$  = index for panel type, screw diameter, screw length, and the replication, respectively, 1 ... 3.

### Preparation and Construction of the Test Cabinets

Test cabinets were constructed of 18-mm-thick PB and 16- and 18-mm-thick MDF panels. A four-sided cabinet consists of a top panel, a bottom panel, and side panels of the same material. In constructing the test cabinets, 3,660 by 1,830-mm full-size sheets of PB and MDF were cut into top, bottom, and side panels. These panels were then cut into final member widths and lengths. The final measurements of each test cabinet were based on the commonly used wall cabinet size of 750-mm height by 300-mm depth by 840-mm width (Fig. 1).

The corner joints of test cabinets were assembled with three screws. No adhesive was used in assembly. Steel Phillips head wood screws with  $40 \pm 3$  degree thread angle were used at the corner joints. A total of nine types of screws, namely, 3.5 by 40, 45, and 50 mm; 4 by 40, 45, and 50 mm; and 5 by 40, 45, and 50 mm, were used in assembling the cabinets. Root diameter, outside diameter, and threads per millimeter, respectively, were  $2.1 \pm 0.20$  mm,  $3.5 \pm 0.25$  mm, 1.6 for the 3.5-mm-diameter screws;  $2.4 \pm 0.25$  mm,  $4.0 \pm 0.3$  mm, 1.8 for the 4-mm-diameter screws; and  $3.0 \pm 0.3$  mm,  $5.0 \pm 0.35$  mm, 2.2 for the 5-mm-diameter screws. Screws were placed in the center of the edges of side panels, which had predrilled pilot holes. Figure 2 shows a typical placement of screws in the four-sided cabinets used in this study. The diameters of the pilot holes were equal to approximately 80 percent of the root diameter of the screws, and the depth of the pilot holes was approximately 75 percent of the penetration of the screws (Eckelman 2003). Diameter and penetration as a function of screw size are given in Table 2. Test cabinets were stored in a conditioning chamber at  $20^\circ\text{C} \pm 2^\circ\text{C}$  temperature and  $65 \pm 3$  percent relative humidity prior to testing.

### Static Tests of Cabinets

Physical and mechanical properties of PB and MDF panels were evaluated using procedures described in ASTM D4442 (ASTM International 2003) and ASTM D1037 (ASTM International 2001). Furthermore, the edge and face

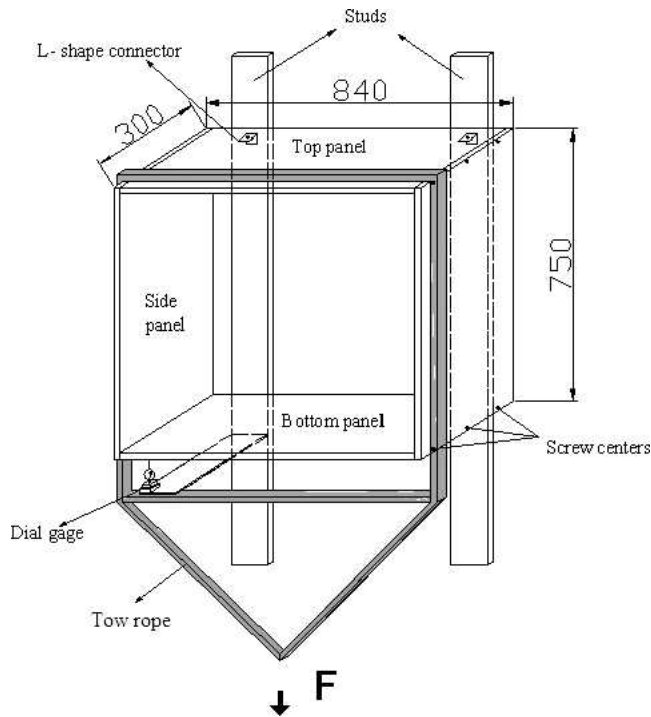

Figure 1.—Test setup for the static test of four-sided cabinets.

screw holding strengths of test panels were evaluated using procedures described by Erdil et al. (2002). The diameter, penetration, and location of the pilot holes at the panel edge were the same for all cabinets. All screw withdrawal tests were carried out on a 50-kN capacity universal testing machine using a loading of 2 mm/min. Ultimate loads were taken as the screw holding strength of the materials. Procedures outlined in American National Standards Institute/Kitchen Cabinet Manufacturers Association (1995) were used in the static tests of the cabinets.

The four-sided cabinets were tested under static loads, and force-deflection diagrams were drawn in order to evaluate the stiffness of the cabinets. Figure 1 shows the loading and supporting conditions of the cabinets.

All tests were conducted using a 50-kN capacity universal testing machine at a loading rate of 6 mm/min. The load was applied by a belt that passed over the top panel and the two sides, meeting under the case where the machine loading head was located. Cabinet stability was maintained by the use of a metal frame positioned over the universal testing machine. The four-sided cabinet was attached to this frame using two parallel 100 by 100-mm studs. These studs were attached to the metal frame with a bolted connection. The four-sided cabinet was mounted on the parallel studs using two L-shaped metal fixtures and screws. The test was designed to allow for failure at corner joints instead of

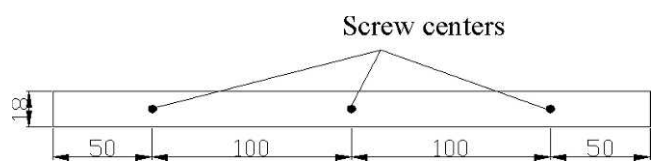

Figure 2.—Screw placements in the corner joints of four-sided cases.

Table 2.—Screw penetrations and diameters of the drilled pilot holes for each screw type used in the corner joints of four-sided cabinets.

Screw diameter (mm)	Screw length (mm)	Diameters of the pilot holes (mm)	Depths of penetration of screws and pilot holes (mm)	
			16-mm thickness	18-mm thickness
3.5	40	2	24	22
	45	2	29	27
	50	2	34	32
4	40	2.5	24	22
	45	2.5	29	27
	50	2.5	34	32
5	40	3	24	22
	45	3	29	27
	50	3	34	32

separation of the entire cabinet from the studs. Since the loading was balanced on both sides of the cabinet, as shown in Figure 1, there was only one dial gage in the left corner of the bottom panel. This was used to measure deflection in the vertical direction from one node after applying the load on a cabinet. Loading was continued until a failure or full separation occurred at the corner joints. During the static tests, failure mode, ultimate failure load, and deflection were recorded. Stiffness values were calculated by taking several measurements of load versus deflection in the elastic, apparently linear range and then fitting them into a regression line by least squares method.

## Results and Discussion

Physical and mechanical properties of materials used in the tests are given in Table 3. Screw holding strength values (from edge and face) for the PB and MDF used in the tests are presented in Table 4. Average ultimate failure loads and stiffness values and their coefficients of variation are given in Table 5.

Results indicated that in general failure loads and stiffness values of the four-sided cabinets were significantly affected by panel type. Cabinets constructed of MDF showed higher failure loads and stiffness values than those constructed of PB. Differences in failure loads and stiffness values can be explained by differences in density and mechanical properties such as bending strength, internal bond (IB) strength, modulus of rigidity ( $G$ ) of panels, and screw holding strength of the construction panel. The density and most strength properties of MDF exceed those of PB.

Mean comparison results pointed out that increasing either screw diameter or screw length tended to positively affect the failure loads and stiffness values. Test results of the previous studies (Zhang et al. 2005; Kasal et al. 2006, 2008; Kasal 2008) agree with this conclusion.

A three-factor analysis of variance (ANOVA) general linear model procedure was conducted to analyze individual data main effects and interactions on both ultimate failure load and stiffness values of test cabinets. Summary of ANOVA results for both ultimate failure load and stiffness are given in Table 6. ANOVA results indicated that for ultimate failure load and stiffness, the main factor effects, two-factor interactions, and three-factor interactions were statistically significant at 5 percent significance level.

**Table 3.—Physical and mechanical properties of particleboard (PB) and medium-density fiberboard (MDF) used in the study.<sup>a</sup>**

Material type	MC (%)	Density (g/cm <sup>3</sup> )	MOR (N/mm <sup>2</sup> )	MOE (N/mm <sup>2</sup> )	G modulus (N/mm <sup>2</sup> )	IB (N/mm <sup>2</sup> )
18-mm PB	7.8	0.67	16.3	2,395	1,101	0.48
16-mm MDF	5.1	0.86	32.6	3,219	1,236	0.61
18-mm MDF	6.3	0.80	30.5	3,532	1,369	0.82

<sup>a</sup> MC = moisture content; MOR = modulus of rupture; MOE = modulus of elasticity; IB = internal bond strength.

Hence, mean comparisons for failure load and stiffness values, the three-factor interactions, were analyzed.

The least significant difference (LSD) multiple comparisons procedure at a 5 percent significance level was conducted to determine the mean differences of ultimate failure load and stiffness values of test cabinets considering the significant three-factor interactions in the ANOVA results.

### Failure Modes

As expected, one failure mode, the opening of corner joints rather than separation of the entire cabinet from the studs, was observed. All joint failures occurred approximately between 60 and 90 seconds into the tests. Furthermore, joints opened up slowly, not suddenly, and screws never broke or bent.

Failure of the joints in all cabinets initiated with the screw heads crushing into the face member, followed by the edge splitting in the transverse direction around the screws. In the cabinets constructed with PB, the amount of core material taken out was significantly more than those constructed with MDF. The amount of edge splitting around the screws in the MDF cabinets was considerably more than those of PB cabinets.

The screws in the corner joints created circular influence zones having a radius of approximately 30 to 40 mm and approximately 50 to 60 mm in the PB and MDF cabinets, respectively. The splits and fractures occurred within these influence zones. None of the influence zones overlapped, but the area of the zone increased with increasing screw diameter.

Fractures occurred on the bottom surface of the top panel and/or the upper surface of the bottom panel. At the end of the tests, either the top panel or the bottom panel separated from the side panels. These separations generally occurred around the screws located in the corners at the back side of the top panel. In some PB cabinets, the screws sheared toward the edge of side panels.

**Table 4.—Screw holding strengths of materials used in the construction of corner joints of the four-sided cabinets.**

Material type	Screw diameter (mm)	Holding strength (N) <sup>a</sup>	
		From edge	From face
18-mm PB	3.5	50.1 (14.3)	80.1 (12.5)
	4	55.8 (12.1)	83.8 (6.8)
	5	113.4 (7.5)	131.5 (6.5)
18-mm MDF	3.5	72.3 (6.9)	82.8 (10.2)
	4	90.6 (12.4)	112.3 (5.7)
	5	187.1 (8.4)	202.8 (7.5)
16-mm MDF	3.5	209.1 (3.9)	136.2 (4.9)
	4	213.4 (5.2)	141.4 (3.3)
	5	224 (1.3)	168.8 (7.5)

<sup>a</sup> Values in parentheses are coefficients of variation.

**Table 5.—Average ultimate failure loads and stiffness values of four-sided cabinets.<sup>a</sup>**

Material type	Screw diameter (mm)	Screw length (mm)	Ultimate failure load (N)	Stiffness (N/mm)	
18-mm PB	3.5	40	617 (2.7)	132 (2.8)	
		45	746 (1.1)	115 (0.5)	
		50	844 (4.2)	126 (1.5)	
	4	40	621 (3.1)	118 (0.7)	
		45	798 (2.8)	147 (1.5)	
		50	772 (1.8)	124 (2.5)	
	5	40	716 (4.7)	139 (3.3)	
		45	906 (2.5)	128 (3.9)	
		50	928 (3.8)	148 (4.8)	
	18-mm MDF	3.5	40	1,694 (2.9)	157 (1.8)
			45	1,495 (5.4)	200 (4.2)
			50	1,979 (2.2)	185 (8.4)
		4	40	1,818 (2.2)	199 (1.2)
			45	1,818 (3.4)	214 (4.6)
			50	2,040 (2.6)	221 (2.1)
5		40	1,893 (0.9)	220 (8.0)	
		45	1,838 (1.1)	219 (3.8)	
		50	1,968 (0.2)	198 (2.9)	
16-mm MDF		3.5	40	1,076 (2.8)	162 (6.9)
			45	1,185 (1.2)	162 (3.6)
			50	1,196 (2.9)	142 (1.8)
		4	40	1,318 (6.6)	160 (1.2)
			45	1,396 (3.3)	164 (5.3)
			50	1,233 (7.3)	180 (5.6)
	5	40	1,340 (6.2)	181 (2.8)	
		45	1,448 (7.1)	176 (4.3)	
		50	1,405 (3.1)	169 (2.2)	

<sup>a</sup> Values in parentheses are coefficients of variation.

### Ultimate Failure Loads

The ranked mean comparisons of ultimate failure loads of tested cabinets, showing the panel material type–screw diameter–screw length interaction, is given in Table 7. These results showed that the highest failure loads were obtained with the 18-mm-thick MDF cabinets joined using 3.5 by 50- or 4 by 50-mm screws. The lowest failure loads were obtained with the 18-mm-thick PB cabinets joined with 3.5 by 40- or 4 by 40-mm screws.

Generally, both 18- and 16-mm MDF cabinets showed higher failure loads than the 18-mm PB cabinets. Results indicated that in terms of the failure loads of the MDF cabinets, 18-mm-thick cabinets were 30 percent stronger than the 16-mm cabinets. Furthermore, failure loads of the 16-mm MDF cabinets were 40 percent higher than those of the 18-mm PB cabinets. These differences in failure loads can be explained by the higher IB strength of the MDF, and therefore higher screw withdrawal strength (Tables 3 and 4).

When the screw diameter or screw length was increased, ultimate failure loads also increased. Particularly, increasing screw diameter from 3.5 to 4 mm and screw length from 40 to 45 mm significantly increased the ultimate failure loads of the cabinets.

For the 18-mm MDF cabinets, screw length was found to have a greater effect on ultimate failure loads than screw diameter. Results showed that there was no significant difference in ultimate failure loads with the 4 by 40-, 4 by 45-, 5 by 40-, and 5 by 45-mm screws. For the 16-mm MDF cabinets, screw diameter had a greater effect on ultimate failure loads than screw length. The optimum screw sizes



Table 6.—Summary of the ANOVA results for ultimate failure loads and stiffness values.

	Source <sup>a</sup>	Degrees of freedom	Sum of squares	Mean squares	F value	P value
Ultimate failure load	A	2	15,340,095.136	7,670,047.5	3,118.0	0.0000
	B	2	437,365.877	218,817.938	88.954	0.0000
	AB	4	104,897.012	26,199.253	10.650	0.0000
	C	2	270,995.136	135,497.568	55.082	0.0000
	AC	4	343,099.309	85,774.827	34.869	0.0000
	BC	4	93,303.901	23,325.975	9.4825	0.0000
	ABC	8	69,851.210	8,731.401	3.5495	0.0023
	Error	54	123,834.667	2,459.901		
	Total	80	16,792,612.247			
Stiffness	A	2	66,508.093	33,254.046	628.37	0.0000
	B	2	6,977.237	3,488.619	65.9213	0.0000
	AB	4	1,741.899	435.475	8.2288	0.0000
	C	2	608.102	304.051	5.7454	0.0055
	AC	4	1,262.509	315.627	5.9641	0.0005
	BC	4	1,810.808	452.702	8.5543	0.0000
	ABC	8	5,515.710	689.464	13.0282	0.0000
	Error	54	2,857.732	52.921		
	Total	80	87,282.90			

<sup>a</sup> A = panel material type; B = screw diameter; C = screw length.

were 4 by 45 and 5 by 45 mm for the 16-mm MDF cabinets. For the 16-mm cabinets connected with 3.5-mm-diameter screws, the increase of screw length also resulted in an increase in ultimate failure load. For the 18-mm MDF, screw diameter had a greater effect on failure loads than screw length. An increase in screw length from 40 to 45 mm significantly increased failure load while there was no

significant difference in failure loads between 45- and 50-mm screw lengths for 18-mm PB cabinets.

### Stiffness

Table 8 shows the ranked mean comparisons of stiffness values for cabinets as a function of material type, screw diameter, and screw length. These results showed that the

Table 7.—Ranked mean comparisons of failure loads of four-sided cabinets.<sup>a</sup>

Material type	Screw diameter (mm)	Screw length (mm)	Ultimate failure load (N)	HG
18-mm MDF	4	50	2,040	A
	3.5	50	1,979	A
	5	50	1,968	AB
	5	40	1,893	BC
	5	45	1,835	C
	4	45	1,818	C
	4	40	1,818	C
	3.5	40	1,694	D
	3.5	45	1,495	E
16-mm MDF	5	45	1,448	EF
	5	50	1,405	FG
	4	45	1,396	FGH
	5	40	1,342	GH
	4	40	1,318	H
	4	50	1,233	I
	3.5	50	1,199	I
	3.5	45	1,185	I
	3.5	40	1,076	J
18-mm PB	5	50	928	K
	5	45	906	KL
	3.5	50	844	LM
	4	45	798	MN
	4	50	772	MNO
	3.5	45	746	NO
	5	40	716	O
	4	40	621	P
	3.5	40	617	P

<sup>a</sup> LSD critical value = 81.19 N. HG = homogeneous group.

Table 8.—Ranked mean comparisons of stiffness values of four-sided cabinets.<sup>a</sup>

Material type	Screw diameter (mm)	Screw length (mm)	Stiffness (N/mm)	HG
18-mm MDF	4	50	222	A
	5	40	220	A
	5	45	217	A
	4	45	214	A
	3.5	45	200	B
	4	40	199	B
	5	50	198	B
	3.5	50	186	C
	5	40	181	CD
16-mm MDF	4	50	180	CD
	5	45	176	CD
	5	50	169	DE
	4	45	164	EF
	3.5	40	162	EF
	3.5	45	162	EF
	4	40	160	EF
	3.5	40	154	FG
	5	50	147	GH
18-mm PB	4	45	147	GH
	3.5	50	142	HI
	5	40	138	HIJ
	3.5	40	131	IJK
	5	45	128	JKL
	3.5	50	126	KLM
	4	50	124	KLM
	4	40	118	LM
	3.5	40	115	M

<sup>a</sup> LSD critical value = 11.91 N/mm. HG = homogeneous group.

highest stiffness values were obtained using 4 by 45-, 4 by 50-, 5 by 40-, and 5 by 45-mm screws in the 18-mm MDF cabinets, and the lowest stiffness values were obtained using 3.5 by 40-, 3.5 by 50-, 4 by 40-, and 4 by 50-mm screws in the 18-mm PB cabinets.

These results showed that higher stiffness was obtained in the 18-mm MDF cabinets compared with the two other panels. Stiffness values for the 16-mm MDF cabinets were higher than those for the 18-mm PB cabinets for all specimens except for the cabinets with 3.5 by 50-mm screws. As might be expected, the stiffness values for the individual panels and cabinets were correlated. The ranked order of the shear modulus ( $G$ ) for the panels and the stiffness values of cabinets were the same. In other words, the rigidity of the individual panels used in the construction of a four-sided cabinet represents the overall stiffness of that cabinet.

Screw diameter was found to have a greater effect on stiffness than screw length. When screw diameter increased the stiffness of cabinets increased, particularly from 3.5 to 4 mm. There was no significant difference between the 45- and 50-mm-long screws, and therefore, 45 mm can be recommended as the optimum screw length for stiffness of cabinets.

### Conclusions

In this study, the effects of panel type, screw diameter, and screw length on ultimate failure loads and stiffness values of four-sided cabinets were investigated. Cabinets were constructed of three different panels and nine different screw sizes. Significant differences were observed in failure loads and stiffness values with respect to panel type, screw diameter, and screw length.

Results indicated that failure load and stiffness of cabinets constructed using 18-mm MDF was higher than those constructed using 16-mm MDF and 18-mm PB. However, 16-mm MDF cabinets showed better performance than 18-mm PB cabinets. Therefore, when producing these cabinets, 16-mm MDF would be recommended instead of the 18-mm PB.

Test results also indicated that cabinets were stronger when either screws diameter or screw length increased. Screw diameter had a greater effect on the stiffness of the cabinets than screw length.

Finally, within the scope of this study, it was concluded that the strongest and most rigid four-sided cabinets were constructed using 4-mm-diameter and 50-mm-long screws when the panel material was 18-mm-thick MDF, 5-mm-diameter and 45-mm-long screws when the panel material was 16-mm-thick MDF, and 5-mm-diameter and 50-mm-long screws when the panel material was 18-mm-thick PB.

It was determined that the corner joint construction of four-sided cabinets was more sensitive to the panel type and screw diameter than screw length. This study provides furniture cabinet manufacturers information regarding the effect of joint construction factors, including screw diameter, screw length, and panel type, on the ultimate failure loads and stiffness values of four-sided cabinets. The information can provide insight for those who are engineering cabinet furniture.

### Literature Cited

- American National Standards Institute/Kitchen Cabinet Manufacturers Association (ANSI/KCMA). 1995. Performance and construction standard for kitchen and vanity cabinets. ANSI A161.1. ANSI/KCMA, Reston, Virginia.
- ASTM International. 2001. Standard test methods for evaluating properties of wood-base fiber and particle panel materials. ASTM D1037-99. ASTM International, West Conshohocken, Pennsylvania.
- ASTM International. 2003. Standard test methods for direct moisture content measurement of wood and wood-base materials. ASTM D4442-92. ASTM International, West Conshohocken, Pennsylvania.
- Bachmann, G. and W. Hassler. 1975. The strength of various furniture constructions, their components, and fasteners. Part I. *Holztechnologie* 16(4):210–221.
- Eckelman, C. A. 2003. Textbook of Product Engineering and Strength Design of Furniture. Purdue University, West Lafayette, Indiana.
- Engleson, T. 1973. Summary of investigations of several particleboards properties in the Swedish Wood Research Institute. Swedish Forest Products Laboratory, Stockholm.
- Erdil, Y. Z., J. Zhang, and C. A. Eckelman. 2002. Holding strength of screws in plywood and oriented strandboard. *Forest Prod. J.* 52(6): 55–62.
- Kasal, A. 2008. Effect of the number of screws and screw size on moment capacity of furniture corner joints in case construction. *Forest Prod. J.* 58(6):36–44.
- Kasal, A., S. Sener, C. M. Belgin, and H. Efe. 2006. Bending strength of screwed corner joints with different materials. *Gazi Univ. J. Sci.* 19(3): 155–161.
- Kasal, A., J. Zhang, M. Yuksel, and Y. Z. Erdil. 2008. Effects of screw sizes on load bearing capacity and stiffness of five-sided furniture cased constructed of particleboard and medium density fiberboard. *Forest Prod. J.* 58(10):25–32.
- Kotas, T. 1957. The theoretical and experimental analysis of cabinet structure. Research Report No. 6. Furniture Development Council, London.
- Kotas, T. 1958a. Stiffness of case furniture. *Prezem. Drzenwy.* 10 and 11: 10–14, 15–18, Warszawa.
- Kotas, T. 1958b. A Design Manual for Case Furniture. Pergamon Press, New York. 49 pp.
- Lin, S. C. and C. A. Eckelman. 1987. Rigidity of furniture cases with various joints construction. *Forest Prod. J.* 37(1):23–27.
- Zhang, J., H. Efe, Y. Z. Erdil, A. Kasal, and N. Han. 2005. Moment resistance of multiscrew L-type corner joints. *Forest Prod. J.* 55(10): 56–63.